

CO₂, temperature and humidity monitor Airbi CO₂AIR

Thank you for choosing an Airbi product.

Before use

- Please read the following information very carefully.
- This manual will help you familiarize yourself with the new device, all its functions and parts, and advise you in case of problems with the device.
- By carefully reading and following the instructions contained in this manual, you will prevent damage or destruction of the device.
- We are not responsible for any damage to the device caused by not following the instructions contained in this manual.
- Pay close attention to the safety instructions.
- Keep the manual for future reference.

Package contents

- CO₂, room temperature and humidity monitor
- USB cable + power adapter
- Instructions for use

Fields of application

- The device is used to check the CO₂ value, internal temperature and humidity for a healthy environment
- Memory for maximum and minimum values
- Display time, date and day of the week
- 2 alarm times
- 4 different symbols indicating the state of the air in terms of concentration of CO₂ values
- Low battery indication
- Automatic or manual calibration of the CO₂ sensor
- For standing or wall mounting

Safety instructions

- The product is intended only for the area of use described in this manual. It should only be used according to these instructions.
- Unauthorized repairs, modifications or changes to the device are prohibited.

ATTENTION! DANGER!

- Risk of fatal electric shock.
- When powered from the mains, connect the device only to a professionally installed socket with a voltage of 230V. The outlet must be easily accessible and close to the device.
- The device or adapter must not come into contact with water or moisture. They are only suitable for use in dry areas.
- If the device or adapter is damaged, do not use it.
- Keep the device out of the reach of persons (including children) who cannot fully appreciate the potential risk of handling electrical equipment.
- In the event of any malfunctions or if the device will not be used for a long time, pull the plug from the socket.
- Use only with the supplied power adapter.

- Connect the adapter to the base first, then plug the adapter into the outlet.
- Do not pull the adapter out of the socket by the cable.
- Route the cable so that it does not come into contact with sharp corners or hot objects.

Attention! Risk of injury:

- Keep the device and batteries out of the reach of children.
- Batteries must not be thrown into fire, short-circuited, disassembled or recharged. There is a risk of explosion!
- Batteries contain dangerous acids. Weak batteries should be replaced as soon as possible to prevent them from leaking into the device.
- Never use a combination of old and new batteries or batteries of different types. Wear protective gloves and goggles when handling leaked batteries.

Description

- | | |
|--|--|
| 1. LCD display | 14. Power adapter input |
| 2. SNOOZE/LIGHT button | 15. Hanging hole |
| 3. Fan symbol | 16. MODE button |
| 4. Alarm symbol | 17. UP button |
| 5. CO ₂ concentration value | 18. DOWN button |
| 6. Air quality status symbol in terms of CO ₂ concentration | 19. ALARM button |
| 7. Temperature display | 20. CO ₂ sensor vents |
| 8. Time display | 21. ALERT button |
| 9. Alarm clock symbol | 22. Battery compartment |
| 10. Humidity display | 23. Stand |
| 11. Low battery indication | 24. Holes for temperature and humidity detection |
| 12. Time display | 25. Power cord end |
| 13. Display the day of the week | 26. Power adapter and USB cable |

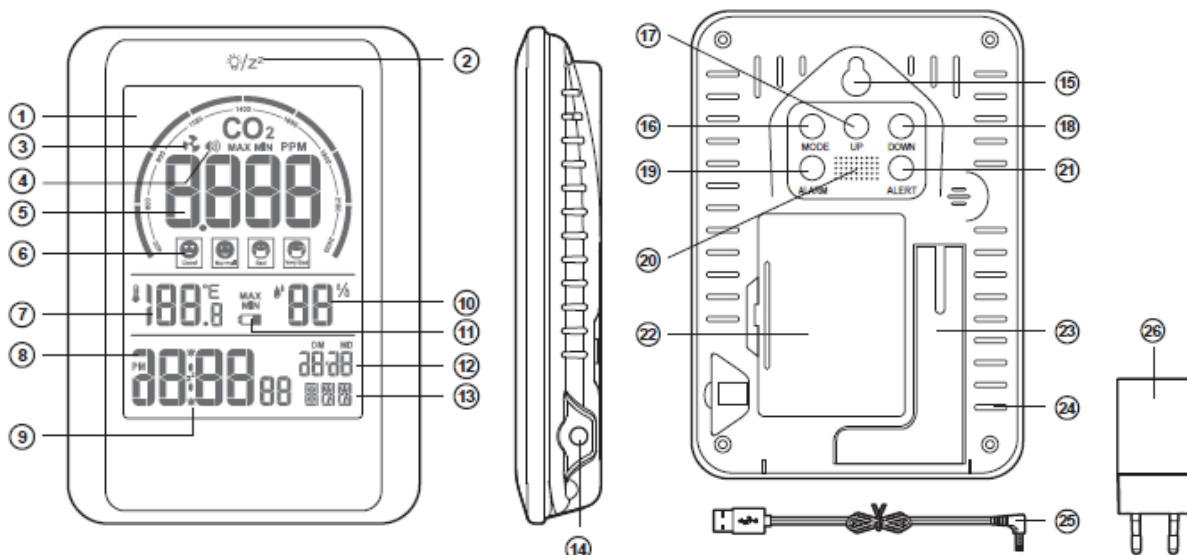

Getting started

1. Operation on adapter

- Plug the DC 5V power adapter into the power adapter input on the device. Plug the other end of the cable with the USB end into a power source (e.g. PC) or into the included adapter

intended for electrical plugs. Operation on the adapter is necessary for continuous measurement of the CO₂ value.

2. Battery operation

- Open the battery compartment and insert 3 new AAA alkaline batteries, paying attention to the correct polarity. If the device is powered by batteries only, the display will show temperature, humidity, time and date. There will be dashes in the CO₂ value segment.
- When operating on batteries, it is also possible to display the CO₂ value for a short time. Press the DOWN button to start a countdown of 30 seconds, after which the CO₂ sensor will be switched on. The CO₂ value will be displayed for 1 minute and during this time it will measure the CO₂ value 10 times. After that, dashes will appear again in the CO₂ segment. This function is practical when you need to find out the CO₂ value in the room at once.
- After inserting the batteries and connecting the adapter, all segments will be displayed briefly and a beep will sound. Then a countdown of 60 seconds will take place to start the CO₂ sensor, and then the temperature, humidity and CO₂ values will appear on the display in normal mode.

NORMAL MODE

Set the time and date

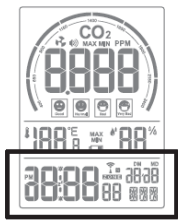

Time and date display



Alarm 1



Alarm 2

- Press and hold the MODE button for 2 seconds to enter the current time and date setting mode. Then the digits will flash in the following order:
year > day-month / month-day > date > 12/24h > hours > minutes
- Use the UP and DOWN buttons to adjust the values. Confirm the setting with the MODE button. Then move on to the next item before doing the complete setup.
- To return to normal mode, press the MODE button in the time and date setting mode or wait 10 seconds without pressing any buttons.

ALARM button and its functions

- In normal display mode, press the ALARM button to display the information in the following order:
- AL1 ON > AL2 ON > AL1 ON + AL2 ON > AL1 OFF + AL2 OFF
- Press once: alarm 1 symbol appears, alarm 1 is active
- Press twice: alarm 2 symbol appears, alarm 2 is active
- Press three times: alarms 1 and 2 symbols appear, alarms 1 and 2 are active
- Press four times: Alarm symbols disappear from the display, alarms are turned off.

SNOOZE/LIGHT button and its functions

- In normal display mode, press the SNOOZE/LIGHT button to turn on the display backlight at 100% brightness for 10 seconds in case of battery power only.
- When using cable power, press the SNOOZE/LIGHT button to adjust the brightness in this order:

high brightness (100%) > low brightness (30%) > backlight off

- If the backlight is off when using battery power, press any button except SNOOZE/LIGHT to turn on the backlight for 10 seconds.
- If the alarm turns on and the backlight is off, press the SNOOZE/LIGHT button to turn on the backlight for 5 seconds.

Setting the alarm time

- The device allows you to set two alarm times:

1. Setting the first alarm

- Press the MODE button once to display AL1.
- Press and hold the MODE button for 2 seconds to enter the wake-up time setting mode. Then the digits start flashing in the following order: AL1 hours > AL1 minutes.
- Use the UP and DOWN buttons to set the hours. Confirm by pressing the MODE button. Then set the minutes and confirm again with the MODE button.
- To turn on the alarm function, press the ALARM button to display the alarm symbol 1 to turn on the alarm 1.
- When the alarm time is reached, an audio signal will ring for 1 minute with a gradually accelerating beep.
- To turn off the alarm, press any button except SNOOZE/LIGHT. If you don't press any button, the alarm will stop sounding after one minute.
- If you press the SNOOZE/LIGHT button while the alarm is ringing, the backlight will turn on for 5 seconds and the snooze alarm will start for 5 minutes.
- To return to normal mode, press the MODE button during the alarm setting mode 1 or wait 10 seconds without pressing the button.

2. Setting the second alarm

- Press the MODE button twice to display AL2.
- Press and hold the MODE button for 2 seconds to enter the wake-up time setting mode. Then the digits start flashing in the following order: AL2 hours > AL2 minutes.
- Use the UP and DOWN buttons to set the hours. Confirm by pressing the MODE button. Then set the minutes and confirm again with the MODE button.
- To turn on the alarm function, press the ALARM button to display the alarm 2 symbol to turn on the alarm 2.
- When the alarm time is reached, an audio signal will ring for 1 minute with a gradually accelerating beep.
- To turn off the alarm, press any button except SNOOZE/LIGHT. If you don't press any button, the alarm will stop sounding after one minute.
- If you press the SNOOZE/LIGHT button while the alarm is ringing, the backlight will turn on for 5 seconds and the snooze alarm will start for 5 minutes.
- To return to normal mode, press the MODE button during alarm setting mode 2 or wait 10 seconds without pressing the button.

Display of MAX/MIN values

- In normal display mode, press the UP button to display the MAX and MIN values of temperature, humidity and CO2 concentration for the given day.
- In normal mode, hold the UP button for 2 seconds to clear the stored MAX and MIN values for the last 24 hours.
- MAX and MIN values are automatically reset every day at 00:00.

CO2 concentration alarm setting

- In normal display mode, the alert function is disabled. Press the ALERT button to turn on/off the sound alarm, the default set value to trigger the alert is 1000ppm. To adjust the alert value, hold the ALERT button for 3 seconds, the CO2 concentration value will flash (range 800 to 2400ppm).
- Use the UP and DOWN buttons to adjust the alert trigger value and confirm it by pressing the ALERT button.
- If the current value exceeds the alert set value, the alarm will ring for 1 minute. The alert symbol will then continue to flash on the display until the CO2 value falls below the alert setpoint, as will the fan symbol to indicate that the current value is higher than the alert setpoint. The fan symbol indicates that the alert value has been exceeded, regardless of whether or not the audible alarm is triggered.
- We recommend not staying in an environment with a CO2 concentration higher than 1000ppm for a long time. If possible, ventilate the room if it is above 1000ppm.

Calibration of the CO2 function

- The device is factory-calibrated to a CO2 concentration of 400ppm. After start-up, the new device must be placed in a well-ventilated area with a concentration of 400ppm for approximately 1 hour to successfully calibrate the sensor, provided that no manual calibration of the minimum measured value is performed during the 7 days of continuous measurement.

1. Automatic calibration of the CO2 sensor

- The device is equipped with a smart sensor, so it performs an automatic calibration to avoid inaccurate measurement, based on the lowest measured CO2 value in the last 7 days of continuous measurement.

2. Manual calibration of the CO2 sensor

- We recommend performing this calibration on a clear, sunny day with sufficient ventilation, when the CO2 concentration reaches approx. 400ppm. Do not calibrate in an environment with an unknown CO2 concentration!
- Disconnect the device from the power supply and connect it again. Then hold the MODE and DOWN buttons at the same time for 3 seconds to enter the calibration mode. After the sound signal sounds and the message "CAL" is displayed, indicating the successful start of the calibration process, you can release the MODE and DOWN buttons. After that, the device needs 4 minutes for manual calibration.
- If the process is successful, the message "PASS" will be displayed. Then the CO2 value will be displayed, now disconnect the device from the power supply again and connect it back. The device is ready for use.
- If the process is not successful, the message "Err" will be displayed. If this happens, repeat the process again.

Display and indication of CO2 concentration

- The CO2 concentration will be measured every 6 seconds. A normal CO2 value is between 400 and 2400ppm. If the concentration falls below 400ppm, the value 400ppm will be displayed. If the value exceeds 5000ppm, the value 5000ppm will be displayed.

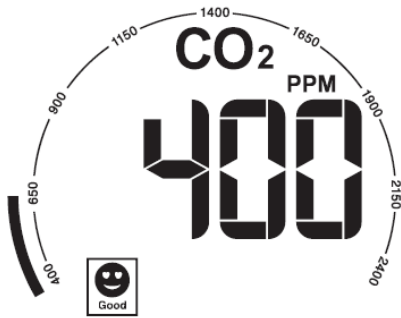

400-650ppm: good

- The CO2 concentration is low, the corresponding symbol will be displayed.

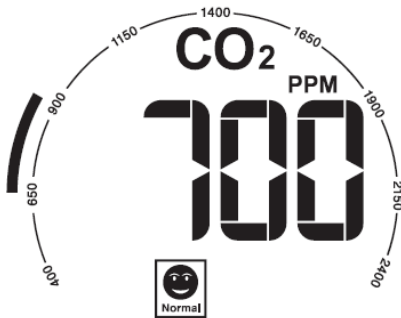

651-900ppm: normal

- The CO2 concentration is normal, the corresponding symbol will be displayed.

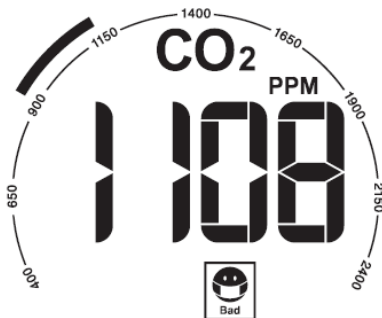

901-1650ppm: bad

- The CO2 concentration is high, the corresponding symbol will be displayed.

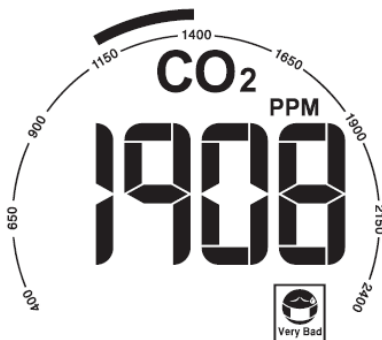

1651-2400ppm: very bad

- The CO2 concentration is very high, the corresponding symbol will be displayed.

Note on calibration

- Do not calibrate on rainy days due to high humidity, which affects the concentration of CO2 in the air.
- Do not calibrate in places with a high concentration of people, high CO2 or near fireplaces and vents.
- When calibrating, keep the device away from people, animals and plants due to the risk of distortion.

- Likewise, avoid contact with perfumes, paints, air fresheners, cigarette smoke, alcohol, chemicals, etc. All these substances can affect the measurement.
- If the instrument measures a value that is not normal, calibrate the instrument.

Indoor temperature and humidity function

- Temperature and humidity are measured every 30 seconds. If the temperature falls below the measuring range, LLL °C is displayed, if it exceeds the range, HHH °C is displayed. If the humidity falls below the measurement range, 20% RH will be displayed, if the range is exceeded, 95% RH will be displayed.

Setting the temperature unit

- If the battery symbol appears on the display when running on batteries, it means that the batteries are dead and need to be replaced with new ones.
- In this case, the message "LO" will be displayed instead of the CO₂ value, indicating the need to replace the batteries or connect the power cable.
- If you do not want to reset the settings of the device when replacing the batteries, it is possible to connect it to the power adapter before replacing the batteries in the device with new ones.

Note: To measure the CO₂ concentration, the device needs a strong electric current, so for continuous measurement of the CO₂ value, it is necessary to power the device using the supplied power cable (using a PC or mains adapter).

PROBLEM SOLVING

No data is shown on the display:

- Make sure the battery is installed correctly.
- Replace the battery or connect the device to the power cable.

Incorrect data on the display:

- Perform manual calibration.

If the device still does not work properly, please contact the seller of the product.

DISPOSAL OF THE DEVICE



The product was made from premium materials and components that can be recycled and reused.

Never dispose of empty batteries and rechargeable batteries in household waste.



As a consumer, you are responsible for taking them to an electrical shop or local waste collection point in accordance with your applicable legislation. You protect the environment by doing so.

The symbols of the heavy metals contained are as follows: Cd = Cadmium, Hg = Mercury, Pb = Lead

This device is marked with the European Waste Electrical and Electronic Equipment (WEEE) label.

Please do not dispose of this device in household waste. The user is obliged to take the end-of-life device to the appropriate collection point for electrical waste to ensure that it is processed in accordance with the environment.

TECHNICAL SPECIFICATIONS

Power supply:	Power adapter with USB cable (DC 5V, 1A) or 3x 1,5 AAA alkaline batteries
Sensor CO ₂ :	PAS (photoacoustic spectroscopy sensor) Range: 400-2400ppm Accuracy: +/- 50ppm or +/- 5% Update: every 6 seconds
Measured temperature range:	-9,9°C to +60°C
Temperature measurement accuracy:	+/- 1°C (0 to 40 °C), otherwise +/- 2 °C
Measured humidity range:	20 to 95 % rH
Humidity measurement accuracy:	+/- 5% (40 to 80 % rH), otherwise +/- 8%
Temperature and humidity updates:	every 30 seconds
Dimensions:	118 x 22 x 68 mm
Weight:	72 g (without batteries)

Producer: Bibetus, s.r.o., Loosova 1, Brno 638 00

No part of this manual may be published without the written consent of the manufacturer. Technical data are valid as of the date this manual was printed and are subject to change without prior notice. The latest technical data and product information can be found on our website.

www.airbi.eu
11/2023